

ROTAX®

Repair manual
engine types
377 - 447 - 503 UL

configuration with
contact breaker ignition system
BING carburetor

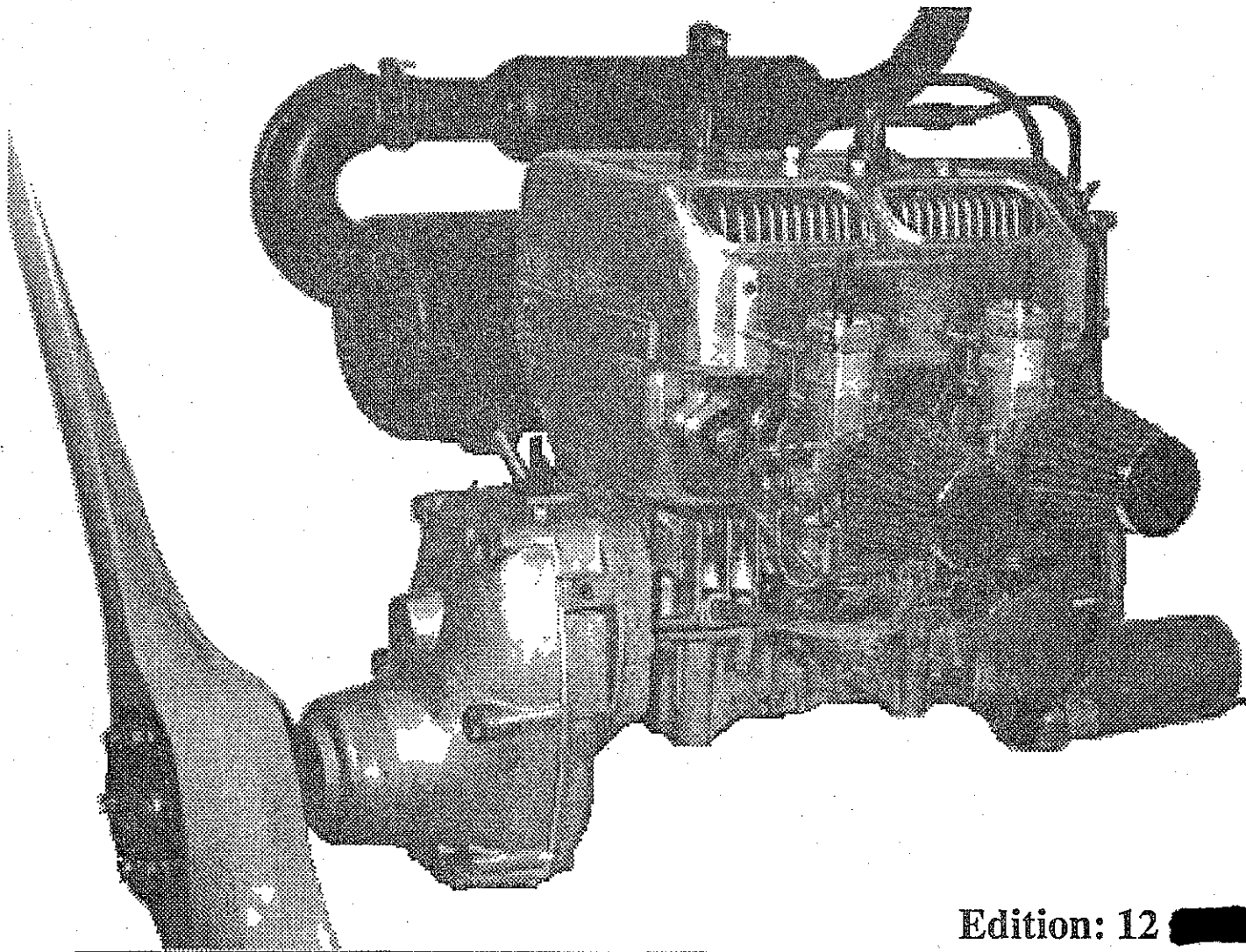

Edition: 12



BOMBARDIER-ROTAX GMBH
MOTORENFABRIK

A-4623 GUNSKIRCHEN - AUSTRIA
Telefon: (0 72 46) 271-0*, Telefax: (0 72 46) 370
Telex: 25546 brgk a, Telegr.: Bombrotax Gunskirchen



REPAIR TOOLS

For professional repair the proper tools are necessary. Apart from the tool kit supplied with the engine, the following special tools are necessary for repair of ROTAX engines type 377, 447 and 503

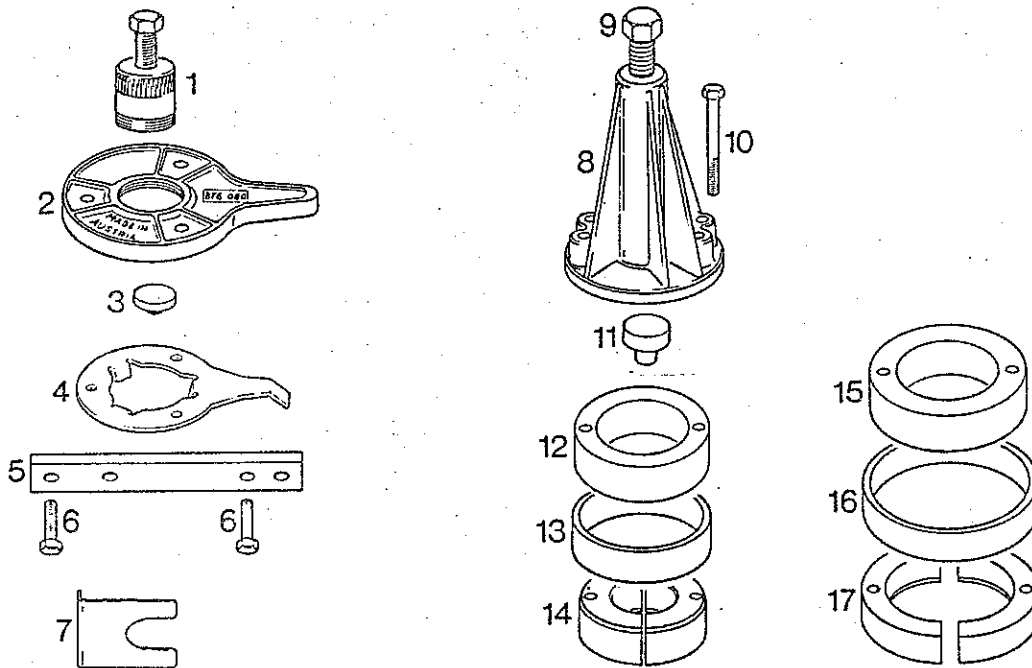

Ill. no.	part no.	description	qty
1	876 065	puller assy. for magneto housing	1
2	876 080	magneto housing fixation tool	1
3	876 557	protection cap for magneto housing puller	1
4	876 357	fan fixation tool	1
5	876 171	cylinder aligning tool	1
6	240 275	hex. screw M8 x 25	2
7	876 620	distance gauge, crankshaft, p.t.o. side	1
8, 9	876 296	puller assy. for crankshaft bearings	1
9	940 755	hex. screw M16 x 1,5 x 145	1
10	841 201	hex. screw M8 x 70	2

11	876 552	protection plug	1
12	876 560	distance ring for puller	1
13	977 480	ring for puller	1
14	276 020	ring half for puller	2
15	876 565	distance ring for puller	1
16	977 490	ring for puller	1
17	977 470	ring half for puller	2

Further tools required

Torque wrench - up to 100 Nm (880 in.lbs)
insert 30 mm, fitting torque wrench
fork wrench 22 mm
socket wrench 8 mm
rubber hammer
hexagon socket screw key 5 mm
hexagon socket screw key 6 mm
hexagon socket screw key 7 mm
screwdriver
Philips blade screwdriver
circlip pliers

DISMOUNTING OF ENGINE

- 1) Clean engine before dismounting.
- 2) Disconnect fuel line from carburetor.
- 3) Screw off carburetor, carburetor socket and intake manifold.
Tools: Screwdriver
socket wrench 13 mm
- 4) Dismount exhaust manifold
Tool: Hexagon socket screw key 6 mm
- 5) Take off fan cover and cylinder cowls
Tools: Socket wrench 10/13 mm
screwdriver

- 6) Screw off rewind starter
Tool: Socket wrench 10

- 7) Unscrew starting pulley and V-belt pulley
Tool: hexagon socket screw key 6 mm
fan fixation tool

- 8) Fix magneto housing holder on the magneto housing with
3 hex. screws M8 x 16
Tools: magneto housing fixation tool 876 080
socket wrench 13

- 9) Unscrew crankshaft nut, mag. side
Tool: Socket wrench 30 with extension (or torque wrench)

- 10) Place protection cap on crankshaft and screw puller into
magneto housing holder, then pull off the magneto housing
(see ill.no. 1)
Tools: Protection cap 876 557
puller for magneto housing 876 065
fork wrench or socket wrench 22

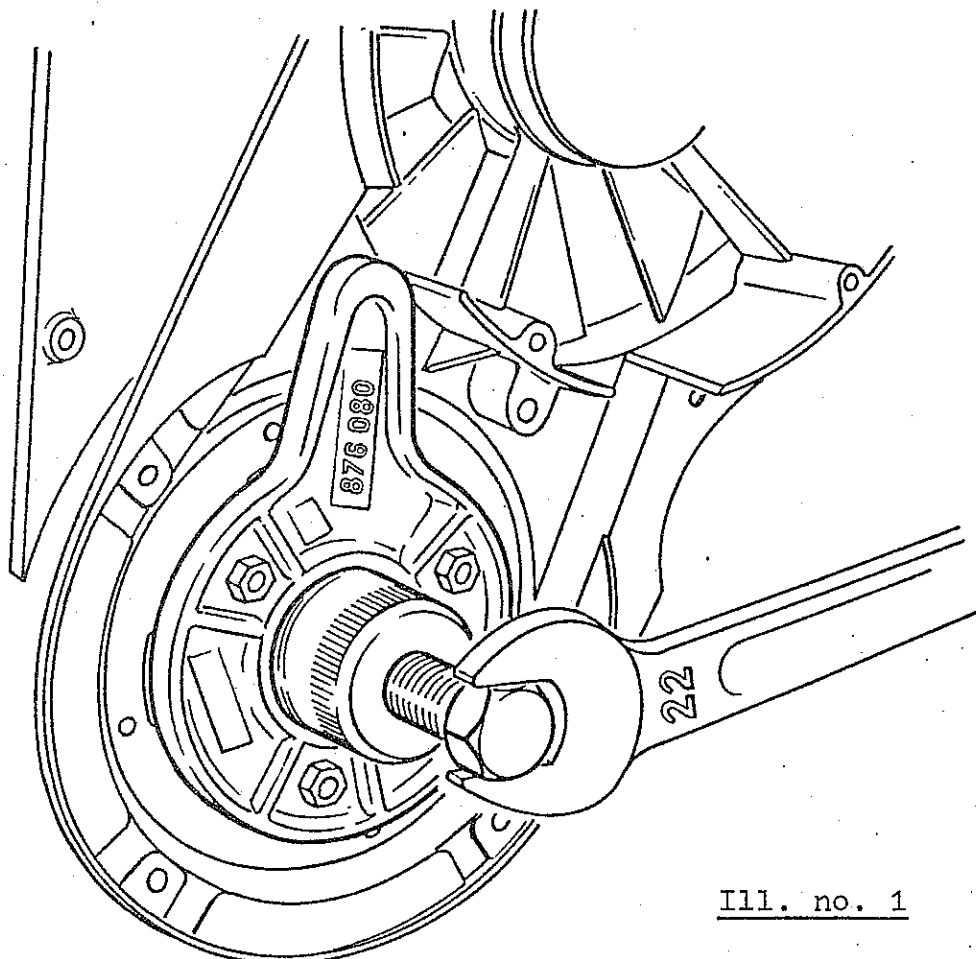

Ill. no. 1

- 11) Dismount ignition coils
Type 503 only: Take off cable grommet and pull out the wiring harness.
Tools: Socket wrench 8
screwdriver
- 12) Screw off fan housing
Tool: Hexagon socket screw key 5 mm
- 13) Mark armature plate position to crankcase for re-assembly.
Screw off armature plate, remove cable grommet and pull through wiring harness.
Tools: Chisel
Hexagon socket screw key 4 mm
- 14) Unscrew cylinder head nuts
Tool: Socket wrench 13 mm
- 15) Mark cylinder heads, cylinders and pistons as they are paired.
- 16) Take off cylinder heads, cylinder head gaskets, cylinders and cylinder base gaskets.
- 17) Cover opening in crankcase with a clean cloth.
- 18) Remove piston pin circlips (see ill. no. 2)
Tool: Small screwdriver, shaped as shown on illustration. 2.

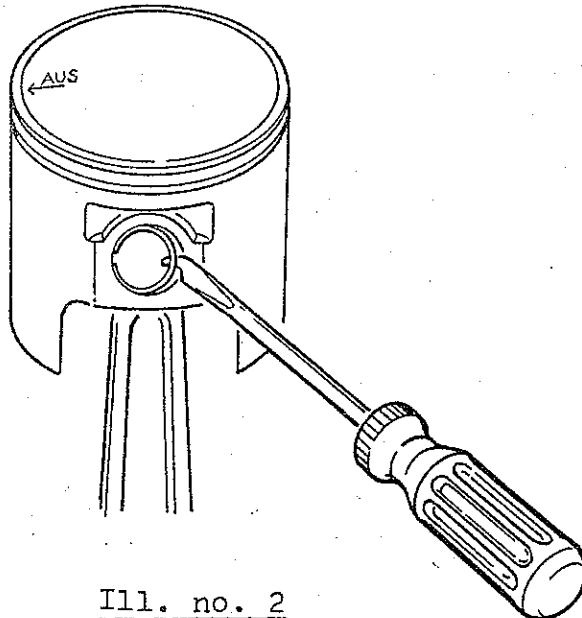

Ill. no. 2

19) Push piston pins out by hand.

Tool: Suitable punch for piston pin.

Attention:

When pushing out the piston pin, the piston must be firmly held by hand to prevent bending of the connecting rod.

20) Remove needle cage.

21) Dismount crankcase and remove crankshaft.

Tools: Socket wrench 13 mm
rubber hammer

22) Clean the parts dismantled and check whether they can be used again.

23) Pull ball bearings off the crankshaft (ill. no. 3 shows p.t.o. (power take off) side of crankshaft)

I) P.t.o. side (=power take off)

- a) Put ring halves 276 020 around the bearing.
- b) Put outer ring 977 480 over the ring halves.
- c) Place distance ring 876 560 on to the ring halves and put protection plug 876 552 on the crankshaft.

- d) Screw puller 876 296 with 2 int. hex. screws 841 201 to the ring halves.
- e) Pull off ball bearing by turning the puller screw with wrench 22 mm to the right. Allow bearings to turn while pulling.

II) Magneto side

- a) Put ring halves 977 470 around the bearing.
- b) Put outer ring 977 490 over the ring halves.
- c) Place distance ring 876 565 on to the ring halves and put protection plug 876 557 on the crankshaft.
- d) Screw puller 876 296 with 2 int. hex. screws 841 201 to the ring halves.
- e) Pull off ball bearing by turning the puller screw with wrench 22 mm to the right. Allow bearing to turn while pulling.

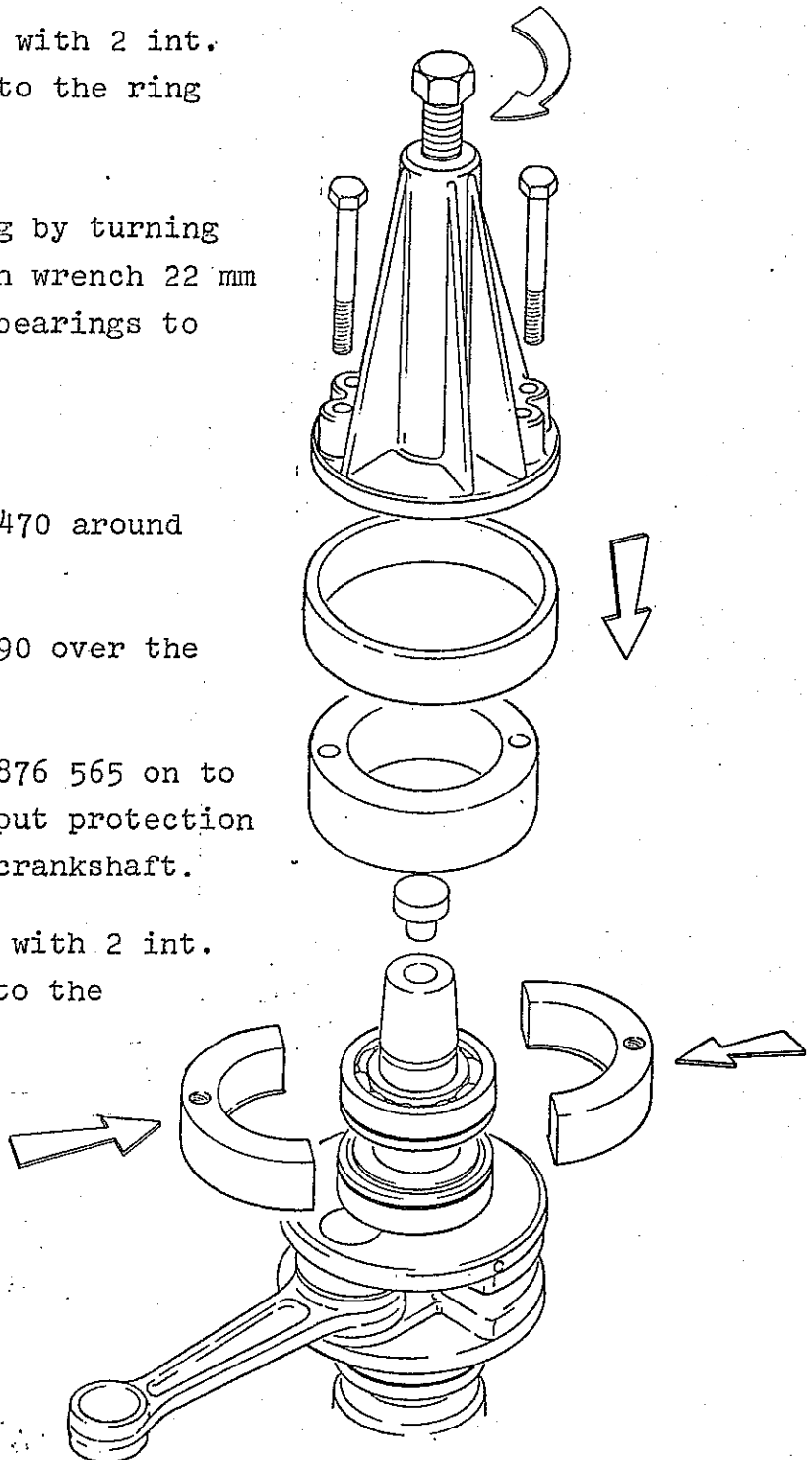

24) Checking the crankshaft

First check whether the 2 centering holes on the crankshaft are in order. If damaged, rework them. Place crankshaft between centers of a lathe or similar device and check crankshaft for centricity. ~~Maximum allowable out of~~ round 0,08 mm (0,003 in) measured with a dial gauge on the bearing seats. If out of round exceeds 0,08 mm (0,003 in), the crankshaft has to be re-aligned. This kind of job should be done by experts only.

In case of excessive radial clearance of the con rod big end bearing or if the crankshaft is in any other way defective, the crankshaft has to be replaced.

ENGINE RE-ASSEMBLY

- 1) Place distance gauge 876 620 on crankshaft, p.t.o. side, and press one ball bearing on to the crankshaft (balls showing towards crankblade, back of the cage showing towards shim 827 715, see spare parts list).
- 2) Mount shims and distance tube, press second ball bearing on to the crankshaft (back of cage showing to the shim).

Attention:

Apply pressure only to inside ring of ball bearing. Use suitable tube. In any case of pressing on bearings, place a mounting support between crankshaft blades (see ill. no. 4). The ball bearings have to be warmed up to $70 \div 80^{\circ}\text{C}$ before pressing them on.

Tools: Suitable pressing device
(hammer)

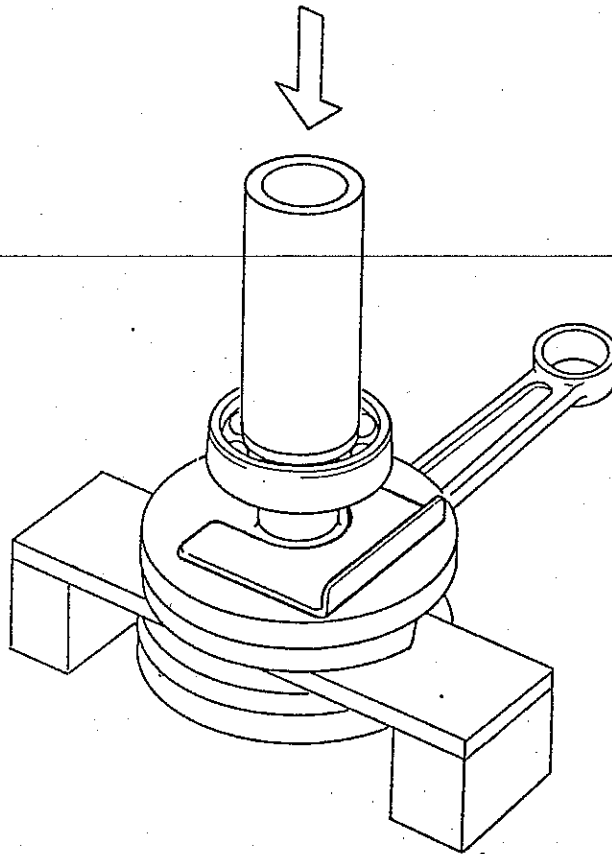

Ill. no. 4

- 3) Press ball bearing, magneto side, fully down, so that the back of the cage shows towards the crankblade.
- 4) Fill oil seals with high melting point ball bearing grease before mounting them.
- 5) Clean sealing surfaces of crankcase and warm crankcase up to $50 \div 60^{\circ}\text{C}$, mount rubber plugs and place crankshaft in upper half of crankcase. Take care that the oil seals close up flush with outside of crankcase.
- 6) Coat sealing surface of lower crankcase half thinly with LOCTITE 574 orange (899 784). Mount it on upper crankcase half, using a rubber hammer.

- 7) Screw on the armature plate provisionally.

Reason: The crankcase halves have to be pulled together into the correct axial position. If necessary, knock the crankcase halves together with a rubber hammer.

Tool: Hexagon socket screw key 4 mm

- 8) Tighten slightly the hex. screws of the crankcase, loosen fixing screws of armature plate again.

Tools: Hexagon socket screw key 4 mm
socket wrench 13 mm

- 9) Tighten hex. screws of crankcase in a cross sequence (starting from the middle) with $18 \div 24$ Nm ($160 \div 210$ in.lbs)

Tools: Torque wrench
insert 13 for torque wrench

- 10) Insert piston pin needle cages in bore of connecting rod, close crankcase cavity with a clean cloth.

- 11) Warm up piston to $40 \div 50^{\circ}\text{C}$ (arrow on top of piston must show towards exhaust). Take care not to mix up the pistons, cylinders and cylinder heads paired together.

- 12) Insert guide pin for piston pin through the piston hole and connecting rod bore. Take care not to damage the needle bearing.

- 13) Coat piston pin with oil, place it on guide pin and insert it into piston hole. All punch impact must be absorbed by your hand to avoid bending of the rod.

- 14) Secure piston pin with circlips.

Attention:

The circlips must engage in the grooves of the piston. Use new circlips. Insert circlip in such a way that open ends are not over the rectangular slot of the piston, as otherwise the circlip would have to be turned around when disassembling later on. Circlips must sit tightly in the groove.

Tool: Screwdriver shaped as shown on ill. no. 2

15) Mount cylinder base gaskets.

Attention: This gasket is not symmetrical. Place it in the correct position. Take care of the transfer recesses in the crankcase.

16) Lubricate pistons and bring piston rings in correct position (securing pin between ends of piston ring).

17) Press piston rings into the grooves and mount oiled cylinder over the piston.

18) Mount cylinder aligning tool on intake side (see ill. no. 5).

Tools: Cylinder aligning tool 876 171
2 hex. screws 240 275

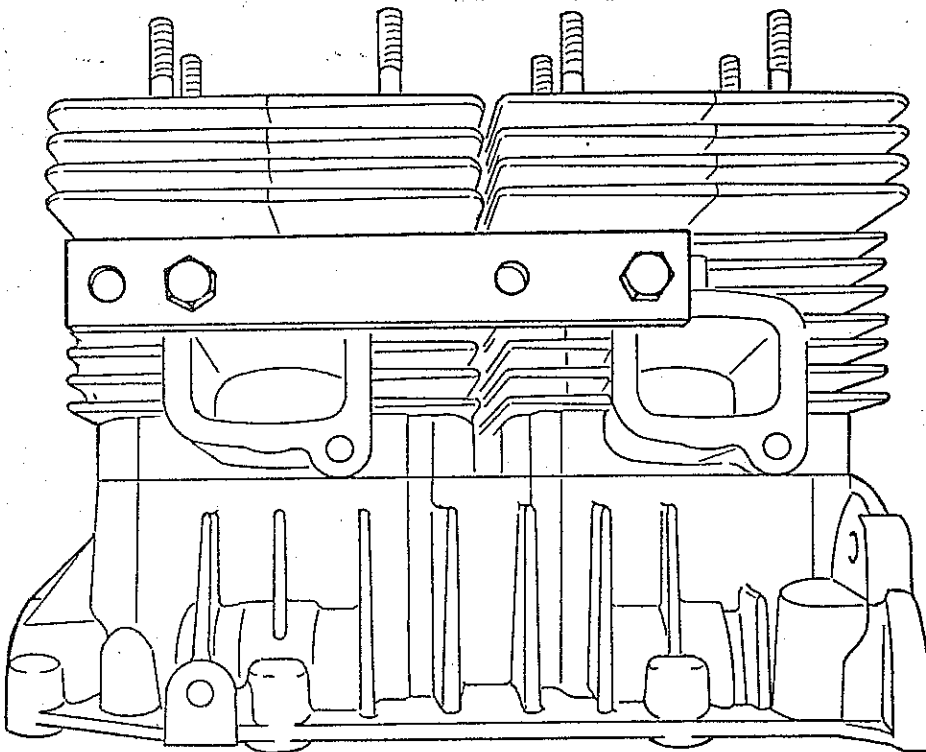

Ill. no. 5

- 19) Mount cylinder head gaskets and cylinder heads. Tighten hex. nuts M8 at 18 ÷ 24 Nm (160 ÷ 210 in.lbs) in a cross sequence.

Tools: Torque wrench
insert 13 mm for torque wrench

- 20) Install wiring harness and mount armature plate so that marks on armature plate and crankcase correspond. If there are no marks on crankcase or armature plate, mount armature plate so that fastening screws are about in the middle of the slots of the armature plate.

- 21) Fix armature plate with allen head screws and insert cable grommet.

Tool: Hexagon socket screw key 4 mm

- 22) Mount Woodruff key on crankshaft taper.

- 23) Mount fan housing with fan assy., pull through wiring harness and insert cable grommet.

Tool: Hexagon socket screw key 5 mm

- 24) Clean crankshaft taper and taper in magneto housing with degreasing agent (e.g. trichloroethylene).

- 25) Coat crankshaft taper with LOCTITE 221 violet (899 785).

- 26) Mount magneto housing with magneto ring on the crankshaft.

Attention: Before mounting magneto housing with magneto ring on the crankshaft, take care that the ignition unit and especially the magnets are clean and free of foreign material.

- 27) Magneto housing nut

Secure thread of hex. nut M22 x 1,5 with LOCTITE 221 violet 899 785 and tighten hex. nut with torque 90 Nm (800in.lbs). After the first 10 hours and then after every 20 hours.

Tools: Torque wrench
insert 30 for torque wrench
magneto housing fixation tool 876 080

- 28) Take off cylinder aligning tool.
- 29) Mount ignition coils, connect cables (see wiring diagram in Operator's Manual).

Tools: Socket wrench 8 mm
screwdriver

- 30) Check resp. adjust ignition (see Operator's Manual).
- 31) Mount V-belt, V-belt pulley and starting pulley, check V-belt tension.

Mounting of V-belt

- a) Mount the fan - in the sequence as per spare parts list (without V-belt!).
- b) Place V-belt diagonally between two blades of the fan, turn the fan until the V-belt has moved into the pulley.
- c) Fix V-belt pulley and starting pulley with one of the 3 screws, but loose. Put V-belt in the pulley groove and turn crankshaft in order to tension the belt and bring the pulleys on their centering. Now the 2 remaining screws can be mounted.

Screw torque: 20 Nm (175 in.lbs)

Tools: Hexagon socket screw key 6 mm
fan fixation tool 876 357

Checking of V-belt tension

The V-belt is correctly tensioned if it can be depressed at normal finger pressure (approx. 50 N = 10 lbs) in the middle between the two V-belt pulleys by 8 ÷ 9 mm (see ill. no. 6).

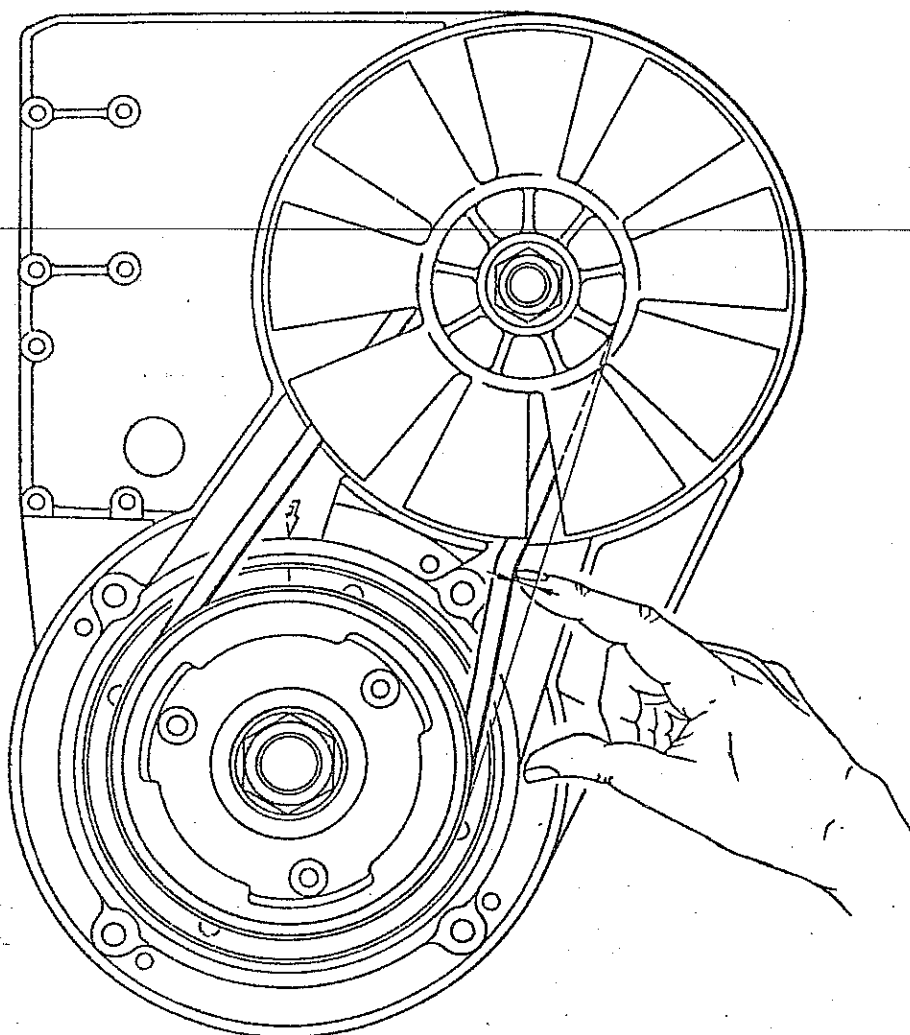

Ill. no. 6

Adjustment of V-belt tension

If the V-belt tension is not within the above tolerance

- a) the tension can be increased by taking off shims between the pulley half and the fan,
- b) the tension can be reduced by adding shims between the pulley half and the fan.

Attention: Never put adjustment shims between protection sheave and fan, because this might cause breakage! (503 only!)

Tools: fan fixation tool (see ill. no. 7)
socket wrench 21/26 mm

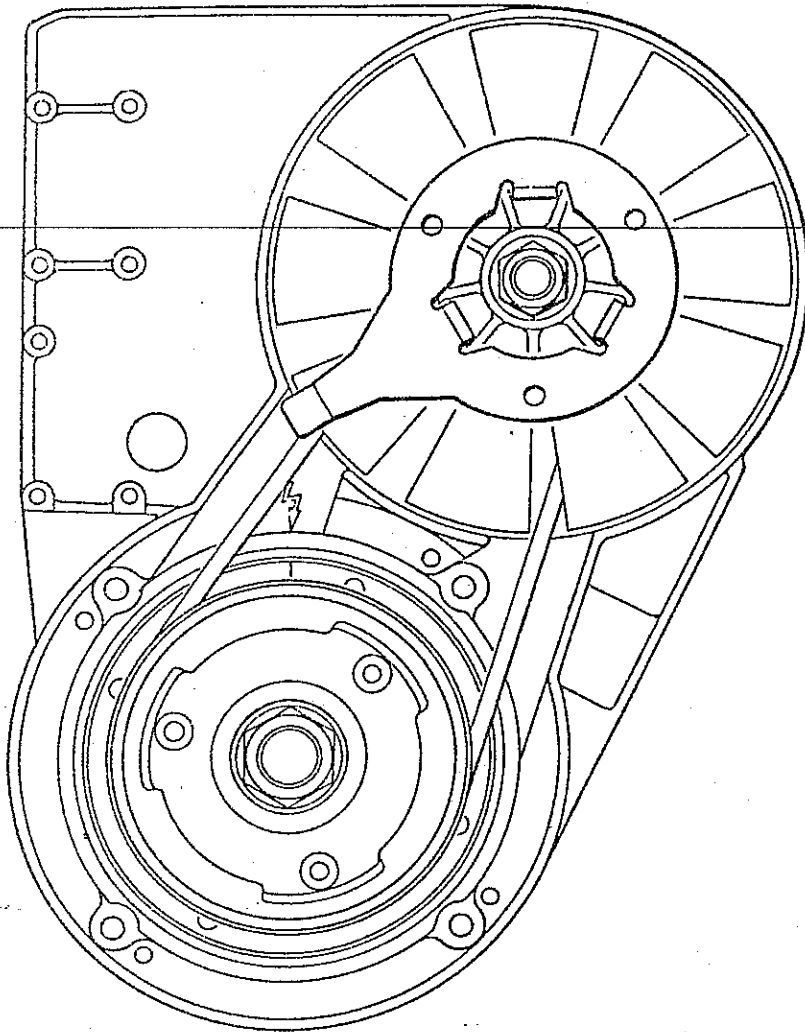

Ill. no. 7

Attention: When mounting the hex. nut M16 x 1,5 care has to be taken not to squeeze the V-belt between the V-belt pulley halves.

Torque 60 ÷ 70 Nm (530 ÷ 620 in.lbs)

Insert V-belt only after having tightened the hex. nut.

DISMOUNTING AND REMOUNTING THE FAN RESP. THE BALL BEARING FOR FAN

- 1) Dismount fan housing.
 - 2) Screw off hex. nut M16 x 1,5.
Take off fan, shims, Woodruff key, pulley half and distance sleeve.
 - 3) Knock out fan shaft with a rubber hammer.
 - 4) Warm up fan housing to $80 \div 100^{\circ}\text{C}$ and knock out ball bearings (knock fan housing onto a plane wooden block).
 - 5) Before pressing in the greased ball bearings, the fan housing has to be warmed up (don't forget shims between the bearings!).
- Then mount the parts in the sequence as dismantled.

REWIND STARTER

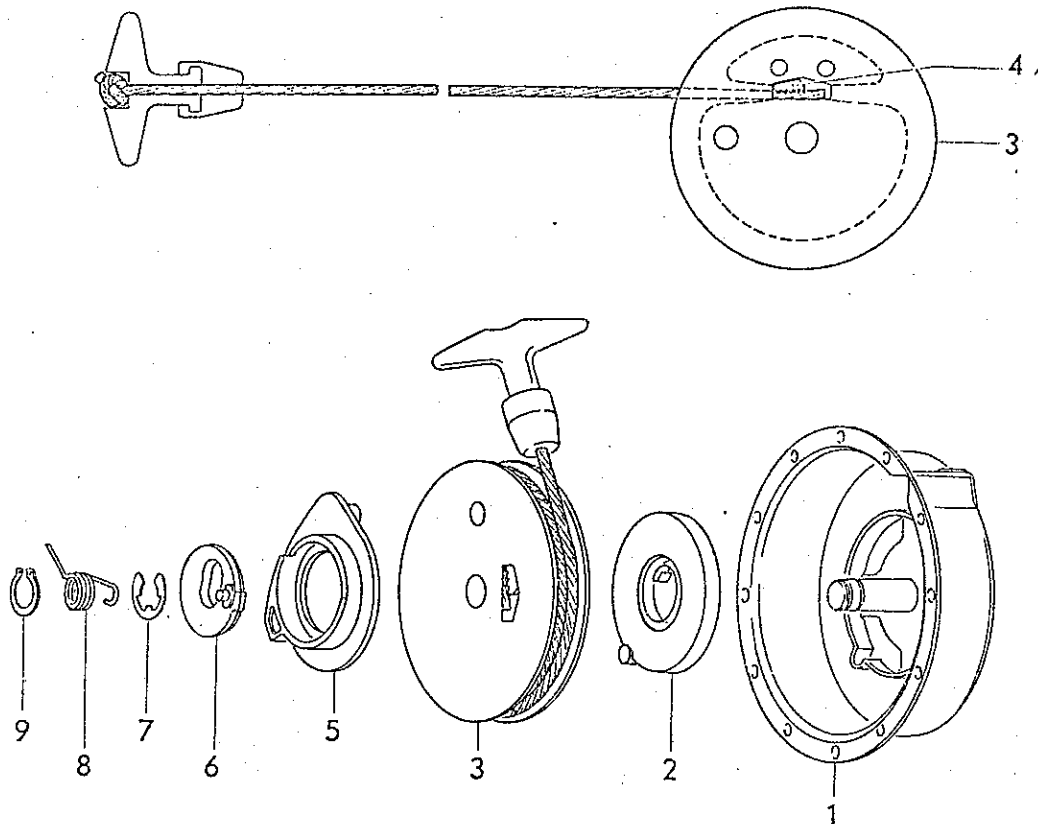

Ill. no. 8